

KONČAR Electrical Engineering INSTITUTE	TEST REPORT EMC and Safety Laboratory		17025-HAA  1129/07
	Br. 21583EMC10001	Page / Pages: 1 / 40	

Test item:

CT Powered Time Over-current relay
 Model: SIGMA XS

Manufacturer:

KONČAR – ELEKTRIČNI APARATI SREDNJEG NAPONA d.d., Borongajska bb, 10000 Zagreb, Croatia.

Test ordered by:

KONČAR – ELEKTRIČNI APARATI SREDNJEG NAPONA d.d., Borongajska bb, 10000 Zagreb, Croatia.

Number of contract:

Order dated 08.12.2009.

Test specification:

Electromagnetic Compatibility Tests

Test methods:

EN 55011:2007
 EN 60255-22-2:1996
 EN 60255-22-3:2000
 EN 60255-22-4:2002
 EN 60255-22-5:2002
 EN 60255-22-6:2001

Location of test:

EMC Laboratory
 OATS Jankomir

Date of test:

08.12.2009. – 22.12.2009.

Date of issue:

11.01.2010.

Additions:

-

Conclusion:

The samples of product comply with the requirements for performed tests.
 Test results are shown in Clause 4.

Test realized by:

Saša Gros, B.Sc.

Vedran Momčilović, B.Sc.

KONČAR - Institut za
 elektrotehniku d. d.
 ZAGREB 6

Head of Laboratory:
 Saša Gros, B.Sc.

The test report shall not be reproduced except in full without the written approval of Končar – Electrical Engineering Institute, Inc.

Address: KONČAR – Electrical Engineering Institute, Inc.
 pp 202, HR-10002 ZAGREB, Fallerovo Šetalište 22
<http://www.koncar-institut.hr>



Phone: 385 (0)1 3667-315
 385 (0)1 3666-351
 Fax: 385 (0)1 3667-309

e-mail: info-iet@koncar-institut.hr

TABLE OF CONTENTS

1.	Device under test / product description	3
	1.1. Identification of Equipment Under Test (EUT)	3
	1.2. Description of Equipment Under Test (EUT)	4
	1.3. Declared EMC Suppression Measures	6
	1.4. Declared EUT Configuration	6
	1.5. Declared EUT location	6
2.	Measurement equipment	9
3.	Used standards	12
4.	Summary of test results	13
5.	Test results	14
	5.1. Emission	14
	5.1.1. Mains Terminal Continuous Voltage Disturbances	15
	5.1.2. Radiated disturbances	19
	5.2. Immunity	21
	5.2.1. Electrostatic Discharge Tests	22
	5.2.2. Radiated Electromagnetic Field Immunity Tests	26
	5.2.3. Electrical Fast Transient/Burst Immunity Test	28
	5.2.4. Surge Immunity Test	31
	5.2.5. Immunity to Conducted Disturbances Induced by Radio Frequency Fields	33
	5.2.6. Power frequency magnetic field immunity test	36
	5.2.7. Pulse magnetic field immunity test	39

The test report shall not be reproduced except in full without the written approval of Končar – Electrical Engineering Institute, Inc.

	TEST REPORT EMC and Safety Laboratory		17025-HAA  11/29/07
	Br. 21583EMC10001	Page / Pages: 3 / 40	

1. DEVICE UNDER TEST / PRODUCT DESCRIPTION

1.1. IDENTIFICATION OF EQUIPMENT UNDER TEST (EUT)

Product: **CT Powered Time Over-current relay**

Model: **SIGMA XS**

Serial No: **094002**

Manufacturer: **KONČAR – ELEKTRIČNI APARATI SREDNJEG NAPONA d.d., Borongajska bb, 10000 Zagreb, Croatia.**

Rating: **Power supply voltage: 48 VDC;
Nominal frequency: 50 Hz;
Simulated current per phase: >6 A;
Working temperature: -25°C - +55°C
Storage temperature: -40°C - +85°C**

Results are valid only for tested device.

The test report shall not be reproduced except in full without the written approval of Končar – Electrical Engineering Institute, Inc.

Address: KONČAR – Electrical Engineering Institute, Inc.
pp 202, HR-10002 ZAGREB, Fallerovo Šetaliste 22
<http://www.koncar-institut.hr>

Phone: 385 (0)1 3667-315
385 (0)1 3666-351
Fax: 385 (0)1 3667-309

e-mail: info-iet@koncar-institut.hr

1.2. DESCRIPTION OF EQUIPMENT UNDER TEST (EUT)

CT Powered Time Over-current relay, model: SIGMA XS, is used for over-current protection. Tested device (EUT) is on a picture 1:



Picture 1: Photo of equipment under test – EUT

Upper view of the EUT, together with the connections established for this simulation of the working conditions, is on a picture 2:

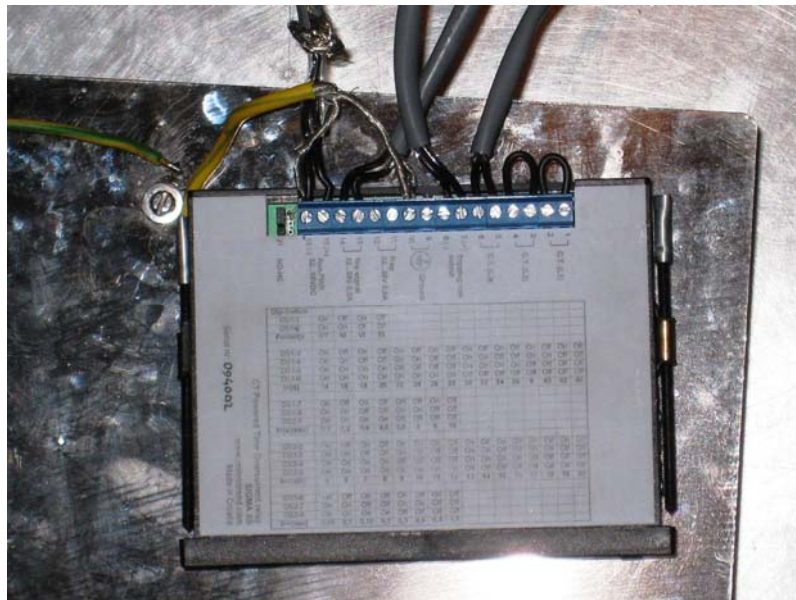

Picture 2: Photo of equipment under test – EUT

The test report shall not be reproduced except in full without the written approval of Končar – Electrical Engineering Institute, Inc.

Auxiliary devices which were used to simulate and/or supply the EUT are on pictures 3 and 4 (following equipment is necessary for normal work of the EUT):



Picture 3: Photo of auxiliary device (DC power supply)



Picture 4: Photo of auxiliary device (over-current simulator)

1.3. DECLARED EMC SUPPRESSION MEASURES

All changes which were necessary can be found on a picture 5 (block scheme):

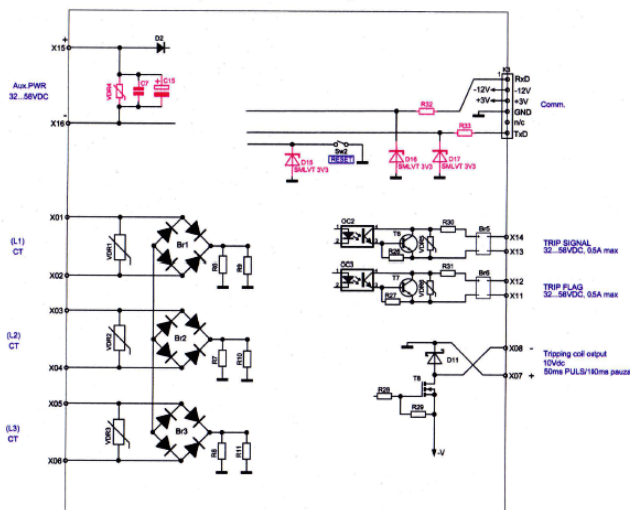

Picture 5: Block scheme of the input circuits (together with the needed changes)

DC power supplies grounded on a negative line of the power supply in accordance with the manufacturer's instructions.

1.4. DECLARED EUT CONFIGURATION

Power supply:

DC power supplies grounded on a negative line of the power supply, in accordance with the manufacturer's instructions.

(2 lines, for the purpose of the emission measurement and some immunity $L \leq 1$ m, unshielded)

Signal lines:

Cables, unshielded, C.T.L3 (3rd phase for example) and TRIPPING COIL OUTPUT are not longer than 3 m, and by the state of the manufacturer, are inside of the case.

Shielded cable, TRIP SIGNAL, $L > 3$ m, grounded on further side of the relay.

WORKING (TESTING) MODE OF THE EUT:

MODE_1: stand-by – continuous monitoring of the current

MODE_2: over-current function activated with the help of the auxiliary device, activation of the auxiliary device (picture 6)

The test report shall not be reproduced except in full without the written approval of Končar – Electrical Engineering Institute, Inc.

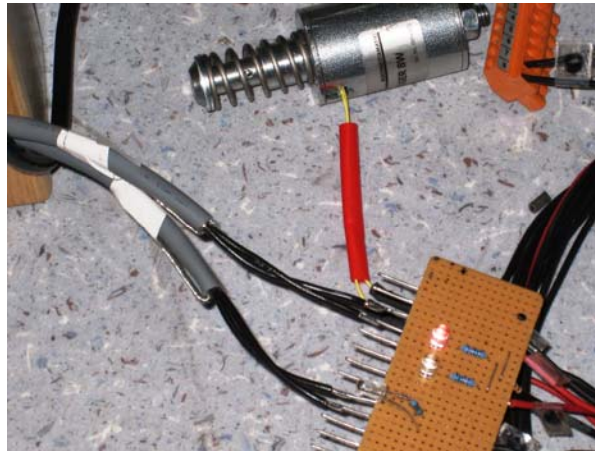

Picture 6: Detection device when over-current function is activated

During immunity testing the following conditions must be accomplished:

- 1) Device must not stop working properly, depending of the performance criteria for the each particularly method.
- 2) LED's must not turn off and communication channel must stay in function, without degradation, depending of the performance criteria for the each particularly method.

In a goal to control all functions of the EUT, during immunity testing the following is evaluated:

- a) state of the LED's
- b) state of the memory, which can be checked by a connection that is not used in a real work, given by the manufacturer
- c) state of the detection device

The test report shall not be reproduced except in full without the written approval of Končar – Electrical Engineering Institute, Inc.

	TEST REPORT EMC and Safety Laboratory		
	Br. 21583EMC10001	Page / Pages: 9 / 40	

2. MEASUREMENT EQUIPMENT

Type	Model	Manufacturer	Serial No.	Končar Id. No.
FARADAY CAGE	B83102-S1-X10	Siemens	-	EMC 21583 03
ESD GENERATOR	NSG 435	Schaffner	2271	D873160
LISN	NSLK8126	Schwarzbeck	126601	602003
EMI RECEIVER	FCLE 1535	Schwarzbeck	107	897834
LOG-PERIODIC ANTENNA	VULB 9163	Schwarzbeck	298	EMC 21583 07 07 02
WIDEBAND RECEIVER	8053	PMM	0220J10750	D845053
WIDEBAND PROBE	EP 330	PMM	1010J10751	EMC 21583 36
EFT GENERATOR	PEFT 4010	Haefely	154688	899682
GENERATOR	UCS 500 M4	EM Test	1202-05	887348
AMPLIFIER	TIA-1000-4	Mini-Circuits	D112299-11	D870994
GENERATOR	PMM 3000	PMM	2130J60502	840463
AMPLIFIER	PMM 6000N	PMM	0100J51106	EMC 21583 06 08 02
POWER RECEIVER	PMM 6600	PMM	2210J60505	EMC 21583 06 08 03
ATENUATOR	BIRD 25A-MFB-06	PMM	0063055	EMC 21583 06 08 04
COUPLING NETWORK	FCC-801-M2-16A	FCC	06023	EMC 21583 06 08 06
GENERATOR	N5183A MXG	Agilent Technologies	N10149	84-2157

The test report shall not be reproduced except in full without the written approval of Končar – Electrical Engineering Institute, Inc.

Address: KONČAR – Electrical Engineering Institute, Inc.
 pp 202, HR-10002 ZAGREB, Fallerovo Šetaliste 22
<http://www.koncar-institut.hr>

Phone: 385 (0)1 3667-315
 385 (0)1 3666-351
 Fax: 385 (0)1 3667-309

e-mail: info-iet@koncar-institut.hr

FIET 40520/9

	TEST REPORT EMC and Safety Laboratory		
	Br. 21583EMC10001	Page / Pages: 10 / 40	

AMPLIFIER	AP32 SV125A	PRANA	0904-0936	84-2488
COUPLING CLAMP	F-203I-23	FCC	501	EMC 21583 06 08 07
COUPLING CLAMP	CDN125	Schaffner	631	EMC 21583 01
COAX CABEL	K0328/F	-	-	-
CURRENT TRANSFORMER	MC 2630	EM test	0506-35	808104
ANTENNA	MS 100	EM test	-	EMC 21583 06 08 11
MOTOR VARIAC	MV 2616	EM Test	V0628101593	902502

MEASUREMENT UNCERTAINTY

Where relevant, the following measurement uncertainty levels have been estimated for tests performed on the EUT as specified in EN 55016-4-2:2004.

This uncertainty represents an expanded uncertainty expressed at approximately the 95% confidence level using a coverage factor of k=2.

Measurement	Value
Conducted disturbance	3.58 dB
Radiated disturbance horizontal polarization (10 m)	4.52 dB
Radiated disturbance vertical polarization (10 m)	4.68 dB

KONČAR Electrical Engineering INSTITUTE	TEST REPORT EMC and Safety Laboratory		17025-HAA  1129/07
	Br. 21583EMC10001	Page / Pages: 11 / 40	

EMC Laboratory is accredited by Croatian Accreditation Agency (HAA) according to HRN EN ISO/IEC 17025:2007.

LIST OF ACCREDITATION USED IN THIS TEST REPORT:

Type of test	Accreditation
Radiated disturbances	Accredited
Mains Terminal Continuous Voltage Disturbances	Accredited
Immunity to electrostatic discharge/ESD	Accredited
Radiated Electromagnetic Field Immunity Test	NOT accredited
Electrical Fast Transient/ Burst Immunity Test	Accredited
Surge Immunity Test	Accredited
Immunity to Conducted Disturbances Induced by Radio Frequency Fields	Accredited
Power frequency magnetic field immunity test	Accredited
Pulse magnetic field immunity test	Accredited

The test report shall not be reproduced except in full without the written approval of Končar – Electrical Engineering Institute, Inc.

Address: KONČAR – Electrical Engineering Institute, Inc.
 pp 202, HR-10002 ZAGREB, Fallerovo Šetalište 22
<http://www.koncar-institut.hr>

Phone: 385 (0)1 3667-315
 385 (0)1 3666-351
 Fax: 385 (0)1 3667-309

e-mail: info-iet@koncar-institut.hr

	TEST REPORT EMC and Safety Laboratory		17025-HAA  1129/07
	Br. 21583EMC10001	Page / Pages: 12 / 40	

3. USED STANDARDS

EN 55011:2007	Industrial, scientific and medical (ISM) radio-frequency equipment - Electromagnetic disturbance characteristics - Limits and methods of measurement
EN 61000-4-2:1995+A1:1998+A2:2001	Electromagnetic compatibility (EMC)-Part 4-2: Testing and measurements techniques: Electrostatic discharge immunity test
EN 61000-4-3:2006	Electromagnetic compatibility (EMC)-Part 4-3: Testing and measurements techniques: Radiated, electromagnetic field immunity test
EN 61000-4-4:2004	Electromagnetic compatibility (EMC)-Part 4-4: Testing and measurements techniques: Electric fast transient/burst immunity test
EN 61000-4-5:2006	Electromagnetic compatibility (EMC)-Part 4-5: Testing and measurement techniques – Surge immunity test
EN 61000-4-6:1996+A1:2001	Electromagnetic compatibility (EMC)-Part 4-6: Testing and measurement techniques – Immunity to conducted disturbances, induced by radio-frequency fields
EN 61000-4-8:1993+A1:2001	Electromagnetic compatibility (EMC)-Part 4-8: Testing and measurement techniques - Power frequency magnetic field immunity test
EN 61000-4-9:1993+A1:2001	Electromagnetic compatibility (EMC)-Part 4-9: Testing and measurement techniques - Pulse magnetic field immunity test
EN 60255-22-2:1996	Electrical relays -- Part 22-2: Electrical disturbance tests for measuring relays and protection equipment -- Section 2: Electrostatic discharge tests
EN 60255-22-3:2000	Electrical relays -- Part 22-3: Electrical disturbance tests for measuring relays and protection equipment - Radiated electromagnetic field disturbance tests
EN 60255-22-4:2002	Electrical relays -- Part 22-4: Electrical disturbance tests for measuring relays and protection equipment - Electrical fast transient/burst immunity test
EN 60255-22-5:2002	Electrical relays -- Part 22-5: Electrical disturbance tests for measuring relays and protection equipment - Surge immunity test
EN 60255-22-6:2001	Electrical relays -- Part 22-6: Electrical disturbance tests for measuring relays and protection equipment - Immunity to conducted disturbances induced by radio frequency fields

The test report shall not be reproduced except in full without the written approval of Končar – Electrical Engineering Institute, Inc.



Address: KONČAR – Electrical Engineering Institute, Inc. Phone: 385 (0)1 3667-315
 pp 202, HR-10002 ZAGREB, Fallerovo Šetaliste 22 385 (0)1 3666-351 e-mail: info-iet@koncar-institut.hr
<http://www.koncar-institut.hr> Fax: 385 (0)1 3667-309

FIET 40520/9

4. SUMMARY OF TEST RESULTS

Test methods	Test parameters	Status																		
EN 55011:2007	<p>Mains Terminal Continuous Voltage</p> <p>Disturbances:</p> <table border="1"> <thead> <tr> <th>frequency(MHz)</th> <th>QP(dB(μV))</th> <th>AV(dB(μV))</th> </tr> </thead> <tbody> <tr> <td>0.15 – 0.5</td> <td>79</td> <td>66</td> </tr> <tr> <td>0.5 – 5</td> <td>73</td> <td>60</td> </tr> <tr> <td>5 – 30</td> <td>73</td> <td>60</td> </tr> </tbody> </table> <p>Radiated disturbances:</p> <table border="1"> <thead> <tr> <th>frequency (MHz)</th> <th>QP(dB(μV/m))</th> </tr> </thead> <tbody> <tr> <td>30 – 230</td> <td>40</td> </tr> <tr> <td>230 – 1000</td> <td>47</td> </tr> </tbody> </table> <p><i>Note: radiated disturbances are measured from a distance of 10 m between measuring antenna and EUT.</i></p>	frequency(MHz)	QP(dB(μV))	AV(dB(μV))	0.15 – 0.5	79	66	0.5 – 5	73	60	5 – 30	73	60	frequency (MHz)	QP(dB(μV/m))	30 – 230	40	230 – 1000	47	Complies
frequency(MHz)	QP(dB(μV))	AV(dB(μV))																		
0.15 – 0.5	79	66																		
0.5 – 5	73	60																		
5 – 30	73	60																		
frequency (MHz)	QP(dB(μV/m))																			
30 – 230	40																			
230 – 1000	47																			
EN 61000-4-2:1995+A1:1998+A2:2001 EN 60255-22-2:1996	<p>Contact discharge: ± 2 kV, ± 4 kV, ± 6 kV Air discharge: ± 2 kV, ± 4 kV, ± 8 kV</p> <p><i>Performance criteria: B</i></p>	Complies																		
EN 61000-4-3:2006 EN 60255-22-3:2000	<p>Freq. band: 80–1000 MHz, 10 V/m; Freq. band: 1000–2700 MHz, 10 V/m; (Unmodulated, r.m.s.). Modulation: 80% AM, 1 kHz</p> <p><i>Performance criteria: A</i></p>	Complies																		
EN 61000-4-4:2004 EN 60255-22-4:2002	<p>5/50 ns T_r / T_h 5 kHz repeating frequency DC power supply: ± 4 kV Signal lines: ± 2 kV Number of impulses: 5 by each polarity</p> <p><i>Performance criteria: B</i></p>	Complies																		
EN 61000-4-5:2006 EN 60255-22-5:2002	<p>1.2/50 μs T_r / T_h DC power supply: ± 2 kV diff.mode (L – N) ± 4 kV comm. mode (L+N – GND)</p> <p><i>Performance criteria: B</i></p>	Complies																		
EN 61000-4-6:1996+A1:2001 EN 60255-22-6:2001	<p>Freq. band: 150 kHz-230 MHz Modulacija: 80% AM, 1 kHz DC power supply: 10 V_{ef} (nemodulirano, r.m.s.) Signal lines: 10 V_{ef} (nemodulirano, r.m.s.)</p> <p><i>Performance criteria: A</i></p>	Complies																		
EN 61000-4-8:1993+A1:2001	<p>Field frequency: 50 Hz Test level: 30 A/m Continuously for 60 seconds.</p> <p><i>Performance criteria: A</i></p>	Complies																		
EN 61000-4-9:1993+A1:2001	<p>Test levels: 100 and 1000 A/m Impulse test 1 and 3 sec.</p> <p><i>Performance criteria: A</i></p>	Complies																		

The test report shall not be reproduced except in full without the written approval of Končar – Electrical Engineering Institute, Inc.

	TEST REPORT EMC and Safety Laboratory		17025-HAA  11/29/07
	Br. 21583EMC10001	Page / Pages: 14 / 40	

5. TEST RESULTS

5.1. EMISSION

Test configuration:

- 1) Emission measurements are found on its maximum values of the EUT during normal working conditions.
- 2) EUT must be adjusted like in real working conditions as close as possible.
- 3) If the device consist an integrated antenna together with the EUT, the testing were accomplished with the same antenna put on its original place.
- 4) If the EUT needs some auxiliary equipment to work properly or to put all functions to action, it is allowed to put that equipment together with the EUT.
- 5) If the device consist of a large number of ports, for the purpose of the testing it is necessary to load sufficient number of inputs/outputs.
- 6) Testing configuration and working conditions must be stated by each test method used.

The test report shall not be reproduced except in full without the written approval of Končar – Electrical Engineering Institute, Inc.

Address: KONČAR – Electrical Engineering Institute, Inc.
 pp 202, HR-10002 ZAGREB, Fallerovo Šetaliste 22
<http://www.koncar-institut.hr>

Phone: 385 (0)1 3667-315
 385 (0)1 3666-351
 Fax: 385 (0)1 3667-309

e-mail: info-iet@koncar-institut.hr

5.1.1. MAINS TERMINAL CONTINUOUS VOLTAGE DISTURBANCES

5.1.1.1. Test requirements

- EN 55011:2007
- Frequency range: 150kHz – 30MHz
- Limits:

frequency (MHz)	0.15 - 0.5	0.5 - 30
limit L (dB(μV)) Quasi-Peak	79	73
limit L (dB(μV)) Average detector	66	60

5.1.1.2. Test configuration

The measurements were performed in a shielded enclosure. EUT was connected to an Artificial Mains Network (LISN). EUT was placed on a stand support and at least 0.5 m from the reference ground plane (wall). EUT was connected via a mains cable to the LISN.

The measurement equipment like test receivers, quasi-peak detector and artificial mains network (AMN) are in compliance with CISPR 16 series standards. The tested object was operated under its rated voltage and its rated frequency.

The tested object was settled on an 80 cm wooden support above the reference ground. The length of the power cord of the tested object was about 1 m. The EUT was set 1 m away from the AMN. The cord longer than necessary to be connected to the AMN was folded forth and back parallel so as to form a bundle with a length between 0.3 m and 0.4 m.

Testing configuration is presented by the picture 8:

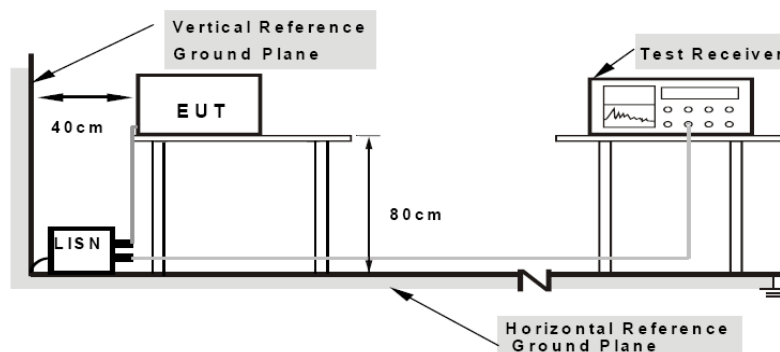

Picture 8: Measurement setup

5.1.1.3. Test procedure

The measurements are made in operational mode producing the largest emission in the frequency range of 150 kHz through 30 MHz.

WORKING (TESTING) MODE OF THE EUT: MODE_1 + MODE_2.

5.1.1.4. Measurement equipment

Type	Model	Manufacturer	Serial No.	Končar Id. No.
LISN	NSLK8126	Schwarzbeck	126601	602003
EMI receiver	FCLE 1535	Schwarzbeck	107	897834

5.1.1.5. Test results

Temperature: 19°C; Humidity: 39%; Air pressure: 995 mbar.

Detector: Quasi-Peak

Phase measured: p1*

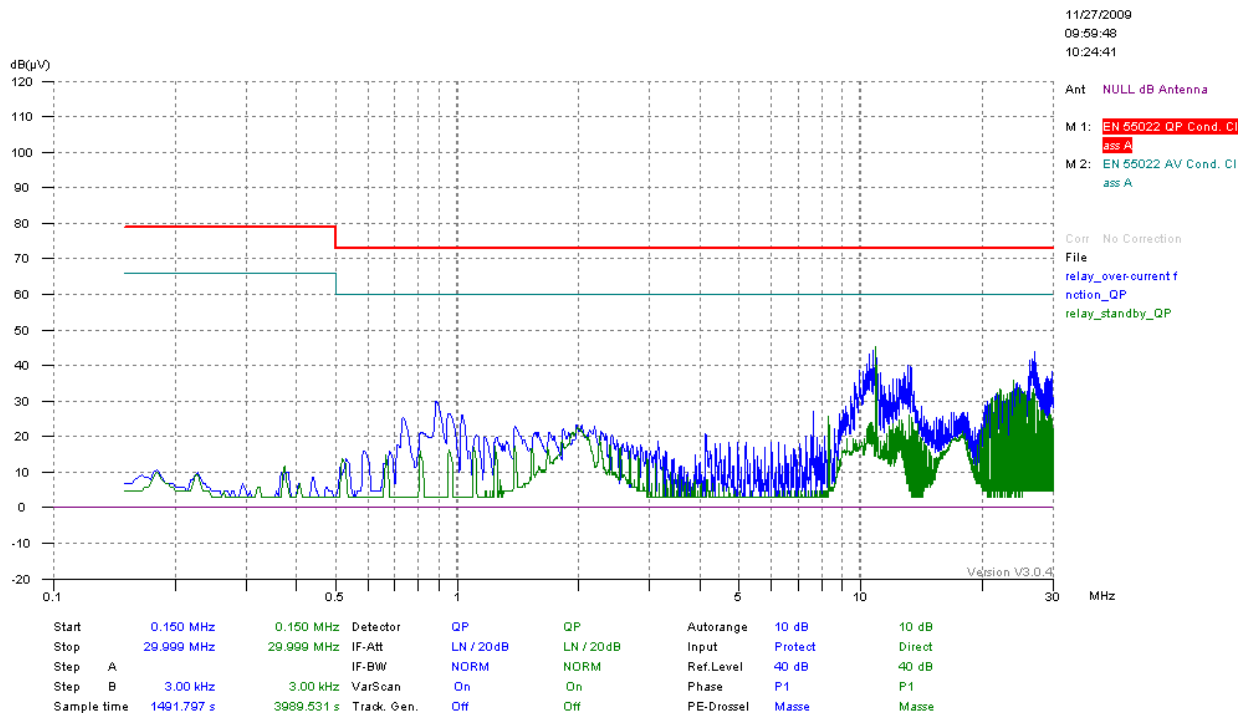

The test report shall not be reproduced except in full without the written approval of Končar – Electrical Engineering Institute, Inc.

	Frequency[MHz]	Level[dB]
1.	10.371	40.26
2.	10.485	43.08
3.	10.614	39.14
4.	10.719	44.16
5.	10.953	42.14
6.	13.074	40.09
7.	13.311	39.82
8.	26.283	41.50
9.	26.529	41.56
10.	26.652	41.87
11.	26.889	43.86
12.	27.132	40.72

Detector: Average
Phase measured: p0*

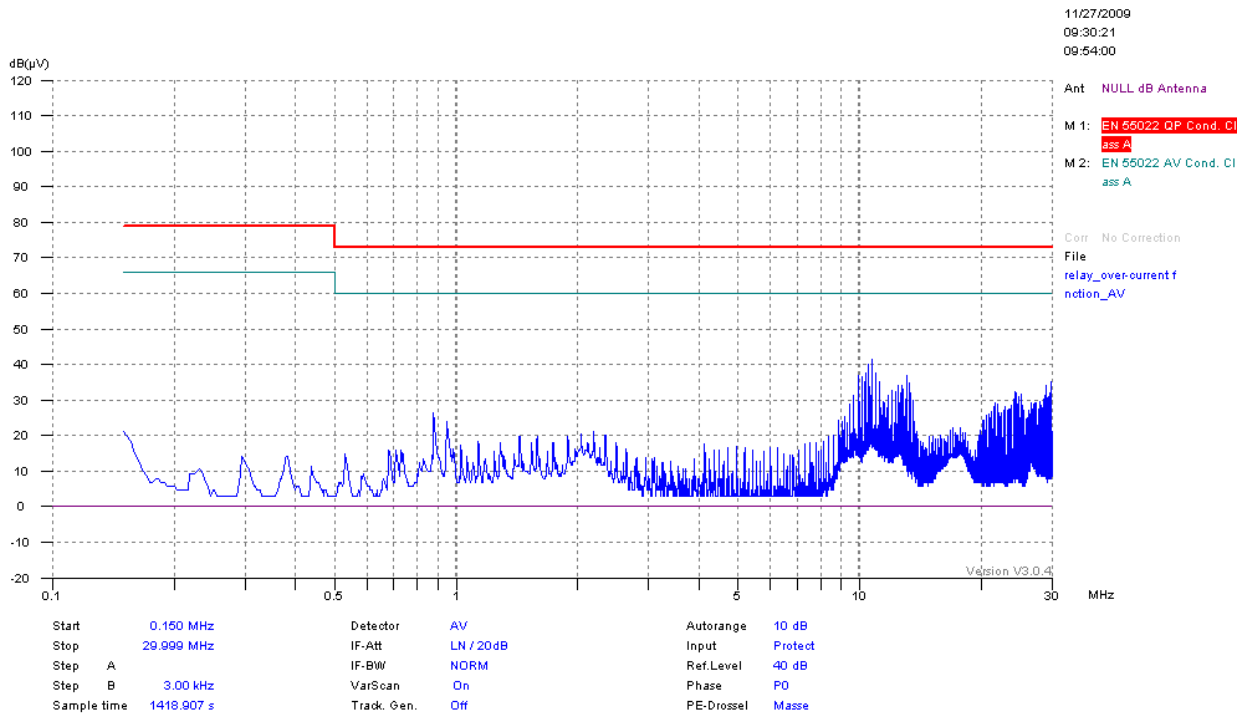

	Frequency[MHz]	Level[dB]
1.	9.894	37.00
2.	10.131	36.63
3.	10.248	35.25
4.	10.365	37.50
5.	10.482	40.01
6.	10.719	41.40
7.	10.950	36.73
8.	10.956	37.50
9.	11.187	35.06
10.	13.071	36.82
11.	13.077	35.39

*NOTE: measurements presented above are the results of a maximum disturbance on both phases included. **Also see clause 1.3. because certain changes were needed.**

The test report shall not be reproduced except in full without the written approval of Končar – Electrical Engineering Institute, Inc.

Photo of the measurement is on a picture 9:



Picture 9: Photo of the measurement setup and testing

Final Test Result: PASS with the conditions given in clause 1.3.

5.1.2. RADIATED DISTURBANCES

5.1.2.1. Test requirements

- 55011:2007
- Frequency band: 30 MHz – 1000 MHz
- Limits:

Frequency (MHz)	30-230	230-1000
Limit L (dB(μV/m))	40	47

5.1.2.2. Test configuration

The measurements were performed at open area site. The measurement antenna was mounted to a non conductive mast capable of moving the antenna through a vertical range of 1 to 4 meters. This mast was positioned such that the distance from antenna to the EUT was 10 meters.

Testing configuration is presented by the picture 10:

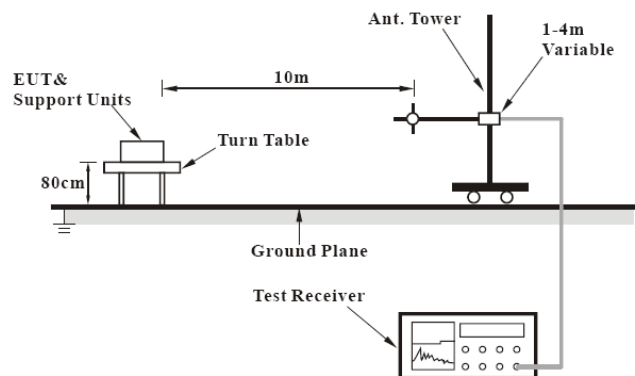



Picture 10: Measurement setup

5.1.2.3. Test procedure

Radiated emissions were investigated over the frequency range of 30 MHz through 1000 MHz. Antenna height was varied from 1 meter to 4 meters. Horizontal and vertical antenna polarizations were evaluated. To ensure maximum radiation electromagnetic field results the EUT was rotated from 0° to 360°. With the exception for this EUT, which is intended to be built in the rack (case), no rotation of the EUT is needed.

WORKING (TESTING) MODE OF THE EUT: MODE_1 + MODE_2.

	TEST REPORT EMC and Safety Laboratory		17025-HAA  11/29/07
	Br. 21583EMC10001	Page / Pages: 20 / 40	

5.1.2.4. Measurement Equipment



Type	Model	Manufacturer	Serial No.	Končar Id. No.
EMI receiver	FCLE 1535	Schwarzbeck	107	897834
Log-periodic antenna	VULB 9163	Schwarzbeck	298	EMC 21583 07 07 02
COAX CABEL	K0328/F	-	-	-

5.1.1.5. Test results

Temperature: 9°C; Humidity: 52%; Air pressure: 1004 mbar.
 Detector: Peak

No values of importance were recorded during the measurements.

Final Test Result: PASS with the conditions given in clause 1.3.

	TEST REPORT EMC and Safety Laboratory		17025-HAA  11/29/07
	Br. 21583EMC10001	Page / Pages: 21 / 40	

5.2. IMMUNITY

WORKING (TESTING) MODE OF THE EUT:

MODE_1: stand-by – continuous monitoring of the current

MODE_2: over-current function activated with the help of the auxiliary device, activation of the auxiliary device (picture 6).

During immunity testing the following conditions must be accomplished:

- 1) Device must not stop working properly, depending of the performance criteria for the each particularly method.
- 2) LED's must not turn off and communication channel must stay in function, without degradation, depending of the performance criteria for the each particularly method.

In a goal to control all functions of the EUT, during immunity testing the following is evaluated:

- a) state of the LED's
- b) state of the memory, which can be checked by a connection that is not used in a real work, given by the manufacturer
- c) state of the detection device

Performance criteria:

A	Equipment under test (EUT) must work as intended during and after test with no degradations allowed.
B	Equipment under test (EUT) must work as intended after test. Any possible degradation must be self-recoverable.
C	Equipment under test (EUT) may be restarted by the user.

The test report shall not be reproduced except in full without the written approval of Končar – Electrical Engineering Institute, Inc.

Address: KONČAR – Electrical Engineering Institute, Inc.
 pp 202, HR-10002 ZAGREB, Fallerovo Šetaliste 22
<http://www.koncar-institut.hr>

Phone: 385 (0)1 3667-315
 385 (0)1 3666-351
 Fax: 385 (0)1 3667-309

e-mail: info-iet@koncar-institut.hr

FIET 40520/9

5.2.1. ELECTROSTATIC DISCHARGE TESTS

5.2.1.1. Test requirements

- EN 61000-4-2:1995+A1:1998+A2:2001
- EN 60255-22-2:1996
- contact discharge: ± 2 kV, ± 4 kV, ± 6 kV
- air discharge: ± 2 kV, ± 4 kV, ± 8 kV
- Number of discharges: 10 to each polarity
- Performance criteria: B

5.2.1.2. Test configuration

The EUT is placed on an 80 cm wooden support above the ground plane. And the minimum distance between the EUT and all other conductive structures except the ground plane beneath the EUT is more than 0.5 m.

The reference ground plane is an aluminium sheet of 0.25 mm minimum thickness. The reference ground plane is connected to the protective earth. The size of the ground plane is 2 m X 2 m.

Vertical coupling plane of dimensions 0.5 m X 0.5 m is placed parallel to and positioned at a distance of 0.1 m from the EUT.

The immunity against electrostatic discharge was tested in accordance with EN 61000-4-2:1995+A1:1998+A2:2001.

Test setup and ESD-generator are according to EN 61000-4-2 which is specified by EN 60255-22-2:1996.

Testing configuration is presented by the picture 11:

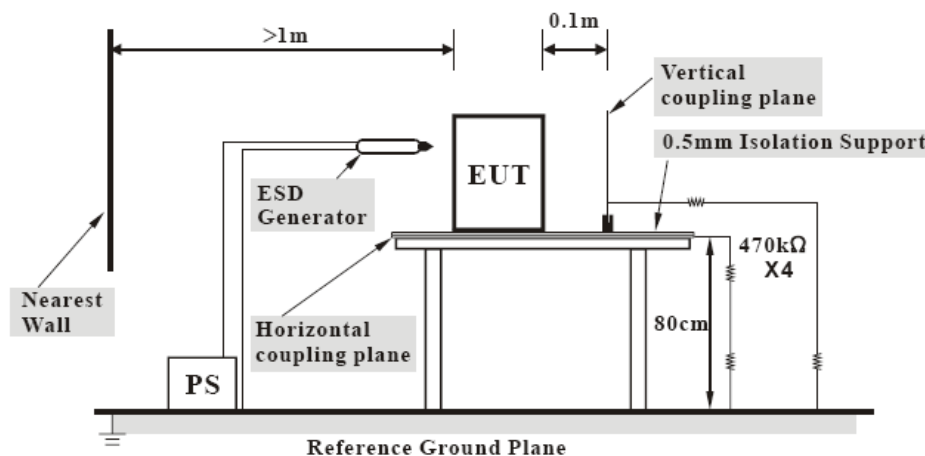

Picture 11: Measurement setup

The test report shall not be reproduced except in full without the written approval of Končar – Electrical Engineering Institute, Inc.

5.2.1.3. Test procedure

The measurements were performed in a shielded enclosure.

WORKING (TESTING) MODE OF THE EUT: MODE_1 + MODE_2.

- a) Electrostatic discharges are made on all surfaces available to the user during normal working conditions of the EUT.
- b) Tests are made with 10 positive and 10 negative polarity discharges at each point used.
- c) Time delay between two discharges is 1s.
- d) ESD generator is put vertically on a surface which is tested, with grounding cable of the generator at least 20 cm distances from the EUT.
- e) Contact discharges are made at non insulated surfaces.
- f) Air discharges are made at distance enough low to generate spark. After one discharge the generator is moved away and the procedure is repeated as stated in b).

5.2.1.4. Measurement Equipment

Type	Model	Manufacturer	Serial No.	Končar Id. No.
ESD GENERATOR	NSG 435	Schaffner	2271	D873160

5.2.1.5. Test results

ATMOSPHERIC CONDITIONS; Temperature: 20°C; Humidity: 41%; Air pressure: 996 mbar

Used points	
1.	2 screws holding the front plastic cover (picture 12, red color)
2.	Reset button (picture 12, green color)
3.	Edge of the plastic cover (picture 12, blue color)

Places of discharges are shown by picture 12:

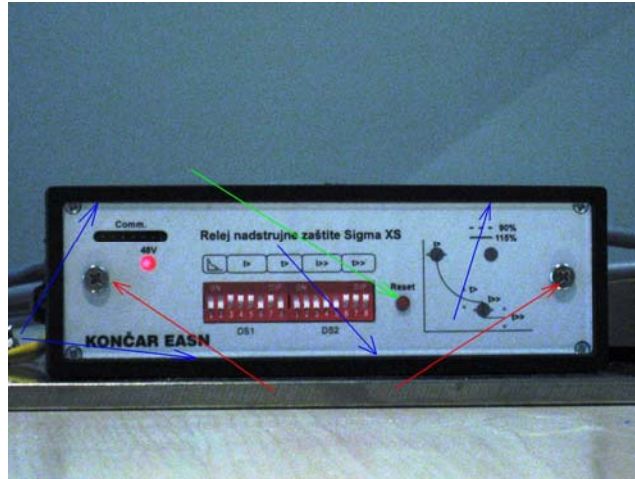

Picture 12: View of the discharge points

a) Contact discharges

- **Direct discharges**

Position	Test Voltage	Result
1.	$\pm 2 \text{ kV}, \pm 4 \text{ kV}, \pm 6 \text{ kV}$	Pass

- **Indirect discharges**

Position	Test Voltage	Result
1.	$\pm 2 \text{ kV}, \pm 4 \text{ kV}, \pm 6 \text{ kV}$ (HSR, VSR)	Pass
2.	$\pm 2 \text{ kV}, \pm 4 \text{ kV}, \pm 6 \text{ kV}$ (HSR, VSR)	Pass
3.	$\pm 2 \text{ kV}, \pm 4 \text{ kV}, \pm 6 \text{ kV}$ (HSR, VSR)	Pass

b) Air discharges

- **Direct discharges**

Position	Test Voltage	Result
1.	$\pm 2 \text{ kV}, \pm 4 \text{ kV}, \pm 8 \text{ kV}$	Pass
2.	$\pm 2 \text{ kV}, \pm 4 \text{ kV}, \pm 8 \text{ kV}$	Pass
3.	$\pm 2 \text{ kV}, \pm 4 \text{ kV}, \pm 8 \text{ kV}$	Pass

The test report shall not be reproduced except in full without the written approval of Končar – Electrical Engineering Institute, Inc.

Photos of the measurements are on the pictures 13 and 14:



Picture 13: Photo of the measurement setup and testing

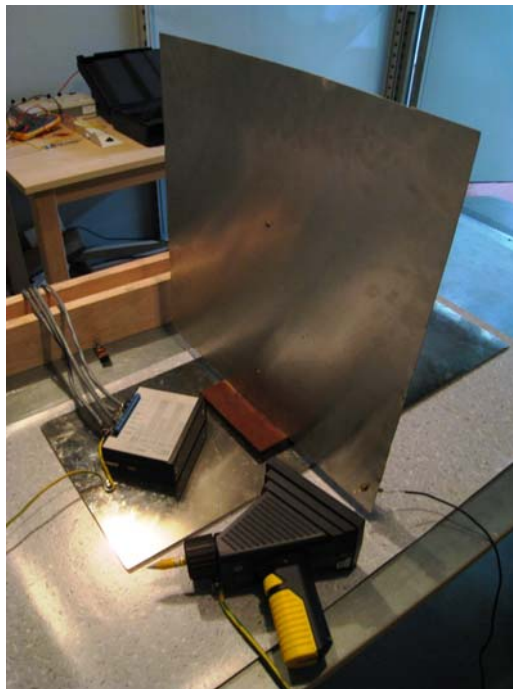

Picture 14: Photo of the measurement setup and testing

Final Test Result: PASS

5.2.2. RADIATED ELECTROMAGNETIC FIELD IMMUNITY TESTS

5.2.2.1. Test requirements

- EN 61000-4-3:2006
- EN 60255-22-3:2000
- Frequency range: 80 MHz – 1000 MHz (10 V/m),
- Frequency range: 1000 MHz – 2007 MHz (10 V/m),
- AM 1 kHz 80%
- Performance criteria: A

5.2.2.2. Test configuration

Test configuration consists of shielded room, signal generator, power amplifier and measurement receiver for registration of electric field strength signal. Test was performed in agreement with manufacturer.

Measurement setup is according to picture 15:

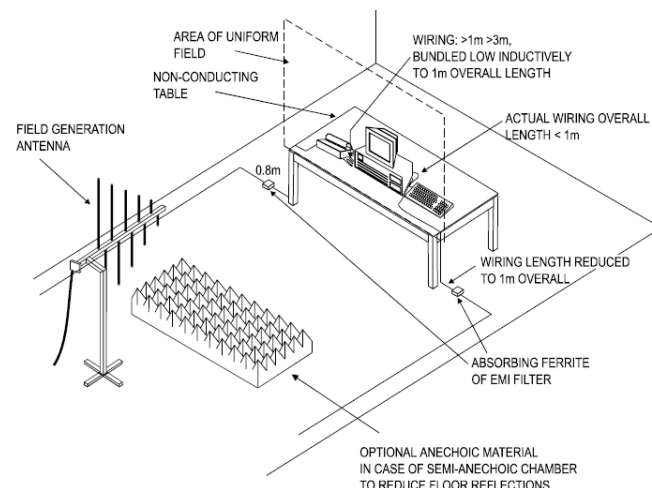

Picture 15: Measurement setup

5.2.2.3. Test procedure

The testing was performed in a shielded room. The transmit antenna was located at a distance of 3 meters from the EUT. The frequency ranges were as stated above. The rate of sweep did not exceed 1.5×10^{-3} decsde/s. During the radiation test, the equipment under test is to be in operation under normal load and power supply, and is connected to external wiring with the manufacturers recommended procedure. The field strength levels as stated above are measured by measurement receiver from received antenna previously positioned in the location of the EUT. The testing was performed with the EUT exposed to both vertical and horizontally polarized fields on each of four sides.

WORKING (TESTING) MODE OF THE EUT: MODE_1 + MODE_2.

With the exception for this EUT, which is intended to be built in the rack (case), no rotation of the EUT is needed.

The test report shall not be reproduced except in full without the written approval of Končar – Electrical Engineering Institute, Inc.

	TEST REPORT EMC and Safety Laboratory		
	Br. 21583EMC10001	Page / Pages: 27 / 40	

5.2.2.4. Measurement Equipment

Type	Model	Manufacturer	Serial No.	Končar Id. No.
AMPLIFIER	TIA-1000-4	Mini-Circuits	D112299-11	D870994
RECEIVER	8053	PMM	0220J10750	D845053
MEASUREMENT PROBE	EP 330	PMM	1010J10751	EMC 21583 36
LOG-PERIODIC ANTENNA	VULB 9163	Schwarzbeck	298	EMC 21583 07 07 02
GENERATOR	N5183A MXG	Agilent Technologies	N10149	84-2157
AMPLIFIER	AP32 SV125A	PRANA	0904-0936	84-2488

5.2.2.5. Test results

ATMOSPHERIC CONDITIONS; Temperature: 20°C; Humidity: 51%; Air pressure: 1004 mbar

Frequency	Polarization	Azm	Field Strength	Remarks
80 – 1000 MHz	V	0	10 V/m	Pass
80 – 1000 MHz	H	0	10 V/m	Pass
1000 – 2700 MHz	V	0	10 V/m	Pass
1000 – 2700 MHz	H	0	10 V/m	Pass

Note: Laboratory is not accredited by HRN EN ISO/IEC 17025 for this test method.

Final Test Result: PASS

5.2.3. ELECTRICAL FAST TRANSIENT/BURST IMMUNITY TEST

5.2.3.1. Test requirements

- EN 61000-4-4:2004
- EN 60255-22-4:2002
- Repetition frequency: 5 kHz
- Test duration: 120 s
- T_r / T_f : 5ns / 50ns
- Amplitude: ± 4 kV (DC power supply)
- Amplitude: ± 2 kV (signal lines)
- Performance criteria: B

5.2.3.2. Test configuration

The EUT is placed on a 80 cm wooden support above the ground plane. And the minimum distance between the EUT and all other conductive structures except the ground plane beneath the EUT is more than 0.5 m.

The length between the coupling device and the EUT is $0.5 \text{ m} \pm 0.05 \text{ m}$.

The cord length of this cable shall be folded to avoid a flat coil and situated at a distance of 0.1 m above the ground reference plane.

The reference ground plane is an aluminium sheet of 0.25 mm minimum thickness. The reference ground plane is connected to the protective earth. The size of ground plane is 2 m X 2 m.

Measurement setup is according to picture 16:

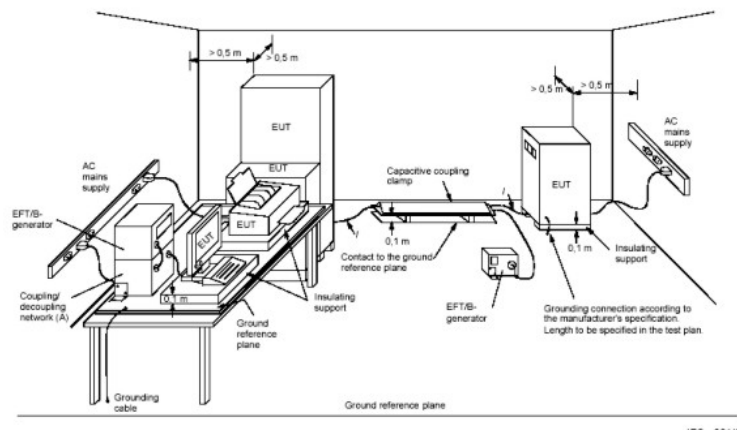

Picture 16: Measurement setup

The test report shall not be reproduced except in full without the written approval of Končar – Electrical Engineering Institute, Inc.

	TEST REPORT EMC and Safety Laboratory		
	Br. 21583EMC10001	Page / Pages: 29 / 40	

5.2.3.3. Test procedure

The immunity against fast transients on DC power and signal lines was tested in accordance to EN 60255-22-4 and EN 61000-4-4.

WORKING (TESTING) MODE OF THE EUT: MODE_1 + MODE_2.

5.2.3.4. Measurement Equipment

Type	Model	Manufacturer	Serial No.	Končar Id. No.
EFT GENERATOR	PEFT 4010	Haefely	154688	899682
COUPLING CLAMP	CDN125	Schaffner	631	EMC 21583 01

5.2.3.5. Test results

ATMOSPHERIC CONDITIONS; Temperature: 20°C; Humidity: 41%; Air pressure: 996 mbar

Line	Voltage	Time of measuring	Result
DC power line L – N	± 4 kV	2 min	Pass
Signal ports Coupling clamp	± 2 kV	2 min	Pass

The test report shall not be reproduced except in full without the written approval of Končar – Electrical Engineering Institute, Inc.

Address: KONČAR – Electrical Engineering Institute, Inc.
 pp 202, HR-10002 ZAGREB, Fallerovo Šetaliste 22
<http://www.koncar-institut.hr>

Phone: 385 (0)1 3667-315
 385 (0)1 3666-351
 Fax: 385 (0)1 3667-309

e-mail: info-iet@koncar-institut.hr

FIET 40520/9

Photos of the measurements are on the pictures 17 and 18:



Picture 17: Photo of the measurement setup and testing



Picture 18: Photo of the measurement setup and testing

Final Test Result: PASS

5.2.4. IMMUNITY TO SURGES

5.2.4.1. Test requirements

- EN 61000-4-5:2006
- EN 60255-22-5:2002
- waveform: 1.2/50 μ s
- Amplitude: ± 2 kV, (L –N, DC power supply)
- Amplitude: ± 4 kV, (L – GND, N – GND, DC power supply)
- Test numbers: 5 positive and 5 negative pulses
- Repetition rate: 1 surge/min or less
- Performance criteria: B

5.2.4.2. Test configuration

The measurements were performed in a shielded enclosure. EUT was placed on 80 cm high support and at least 0.4 m from the reference ground plane (wall).

Measurement setup is according to picture 19:

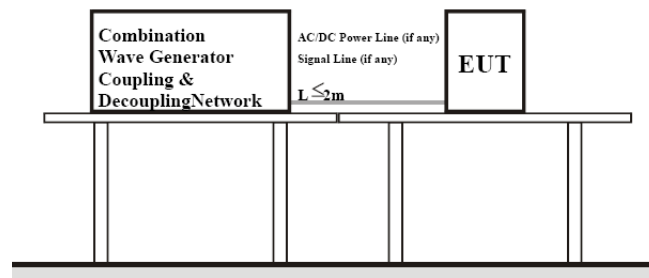

Picture 19: Measurement setup

5.2.4.3. Test procedure

The EUT is placed on a 80 cm wooden support above the ground plane. The immunity against surges to DC power port was tested in accordance to EN 60255-22-5 and EN 61000-4-5.

WORKING (TESTING) MODE OF THE EUT: MODE_1 + MODE_2.

5.2.4.4. Measurement Equipment

Type	Model	Manufacturer	Serial No.	Končar Id. No.
Generator	UCS 500 M4	EM Test	1202-05	887348

5.2.4.5. Test results

ATMOSPHERIC CONDITIONS; Temperature: 20°C; Humidity: 42%; Air pressure: 997 mbar

Line	Measurement Voltage (kV)	Degree (°)	Result
L – N	± 2	0	Pass
L - GND	± 4	0	Pass
L - GND	± 4	0	Pass

Photo of the measurement is on a picture 20:



Picture 20: Photo of the measurement setup and testing

Final Test Result: PASS

5.2.5. IMMUNITY TO CONDUCTED DISTURBANCES INDUCED BY RADIO FREQUENCY FIELDS

5.2.5.1. Test requirements

- EN 61000-4-6:1996+A1:2001
- EN 60255-22-6:2001
- Voltage level on power ports: $10 V_{\text{eff}}$
- Voltage level on signal ports: $10 V_{\text{eff}}$
- Modulation: 1 kHz, 80% AM
- Frequency range: 0.15 – 230 MHz
- Frequency step: 1%
- Dwell time: 1s
- Performance criteria: A

5.2.5.2. Test configuration

The measurements were performed in a shielded enclosure. EUT was placed on 10 cm high support and at least 0.4 m from the reference ground plane (wall). Minimum distance between the EUT and all other conductive structures except the ground plane beneath the EUT is more than 0.5 m.

Measurement setup is according to picture 21:

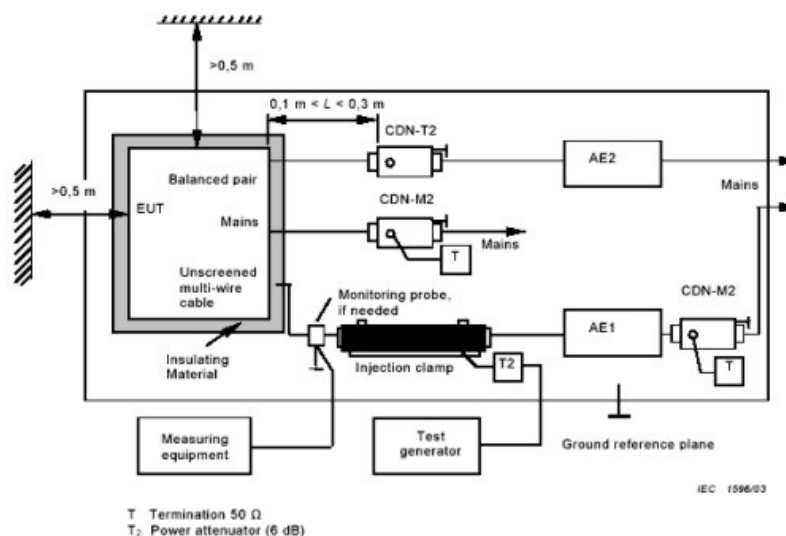

Picture 21: Measurement setup

The test report shall not be reproduced except in full without the written approval of Končar – Electrical Engineering Institute, Inc.

5.2.5.3. Test procedure

The EUT comprised a single unit. The coupling and decoupling networks were inserted on the power supply connection. The coupling and decoupling networks were placed on the ground reference plane, making direct contact with it at about 0.1 – 0.3 meters from EUT.

The cable between EUT and CDN is as short as possible and not bundled nor wrapped.

The height of cable between the EUT and the coupling and decoupling networks above the ground reference plane was 50 mm.

WORKING (TESTING) MODE OF THE EUT: MODE_1 + MODE_2.

5.2.5.4. Measurement Equipment

Type	Model	Manufacturer	Serial No.	Končar Id. No.
Generator	PMM 3000	PMM	2130J60502	840463
Amplifier	PMM 6000N	PMM	0100J51106	EMC 21583 06 08 02
Power receiver	PMM 6600	PMM	2210J60505	EMC 21583 06 08 03
Attenuator	BIRD 25A-MFB-06	PMM	0063055	EMC 21583 06 08 04
Coupling network	FCC-801-M2-16A	FCC	06023	EMC 21583 06 08 06
Coupling clamp	F-203I-23	FCC	501	EMC 21583 06 08 07

5.2.5.5. Test results

ATMOSPHERIC CONDITIONS; Temperature: 20°C; Humidity: 45%; Air pressure: 995 mbar

Port	Voltage	Result
DC power supply: 150 kHz - 230 MHz; 80% AM, 1 kHz	10 V _{eff}	PASS
Signal lines: 150 kHz - 230 MHz; 80% AM, 1 kHz	10 V _{eff}	PASS

Photo of the measurement is on a picture 22:

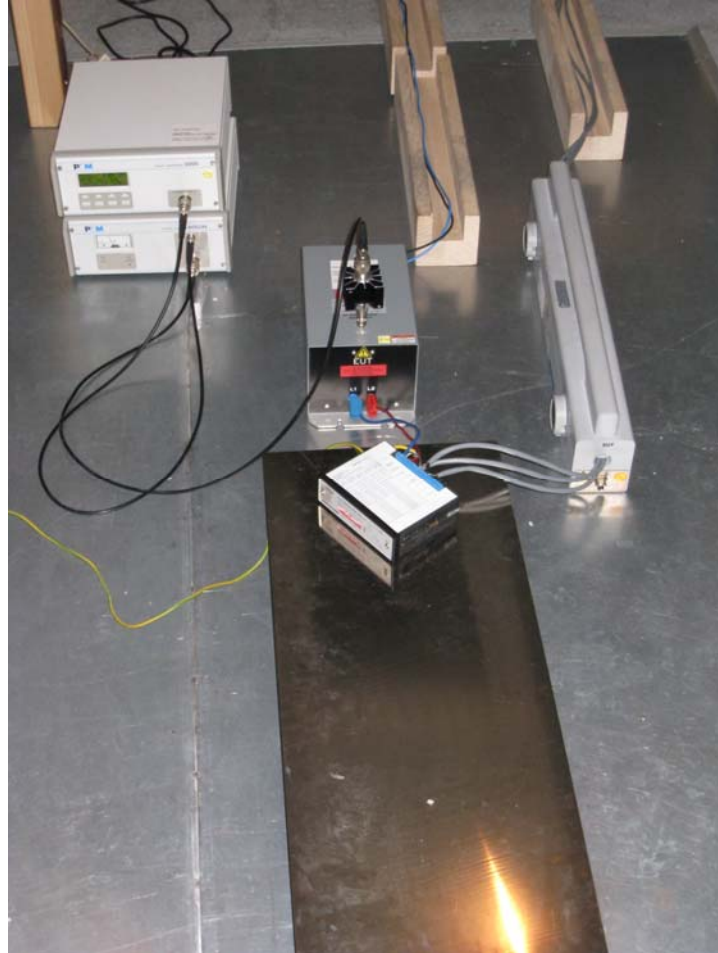

Picture 22: Photo of the measurement setup and testing

Final Test Result: PASS

5.2.6. POWER FREQUENCY MAGNETIC FIELD IMMUNITY TEST

5.2.6.1. Test requirements

- EN 61000-4-8:1993+A1:2001
- Field frequency : 50 Hz
- Test Level : 30 A/m
- Performance criteria: A

5.2.6.2. Test configuration

Measurement setup is according to picture 23:

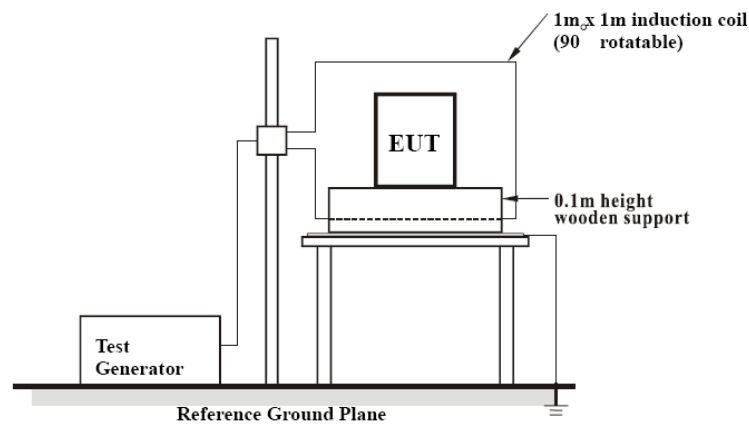

Picture 23: Measurement setup

5.2.6.3. Test procedure

The equipment shall be subjected to the test magnetic field by using the induction coil of standard dimensions (1 m x 1 m). The induction coil shall then be rotated by 90° in order to expose the EUT to the test field with different orientations.

WORKING (TESTING) MODE OF THE EUT: MODE_1 + MODE_2.

5.2.6.4. Measurement Equipment

Type	Model	Manufacturer	Serial No.	Končar Id. No.
GENERATOR	UCS 500 M4	EM Test	1202-05	D887348
ANTENNA	MS 100	EM Test	-	EMC 21583 06 08 11
MOTOR VARIAC	MV 2616	EM Test	V0628101593	902502
CURRENT TRANSFORMER	MC 2630	EM test	0506-35	808104

5.2.6.5. Test results

ATMOSPHERIC CONDITIONS; Temperature: 20°C; Humidity: 42%; Air pressure: 997 mbar

Orientation	Field	Duration	Result
X-axis	30 A/m, 50 Hz	60 sec	Pass
Y-axis	30 A/m, 50 Hz	60 sec	Pass
Z-axis	30 A/m, 50 Hz	60 sec	Pass

Photos of the measurements are on the pictures 24 and 25:



Picture 24: Photo of the measurement setup and testing



Picture 25: Photo of the measurement setup and testing

Final Test Result: PASS

5.2.7. PULSE MAGNETIC FIELD IMMUNITY TEST

5.2.7.1. Test requirements

- EN 61000-4-9:1993+A1:2001
- Field frequency : 50 Hz
- Test Level : 100 A/m, 1000 A/m (pulse)
- Performance criteria: A

5.2.7.2. Test configuration

Measurement setup is according to picture 26:

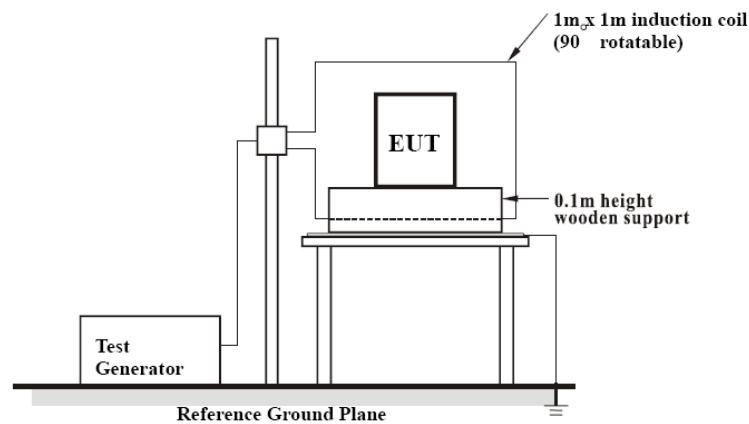

Picture 26: Measurement setup

5.2.7.3. Test procedure

The equipment shall be subjected to the test magnetic field by using the induction coil of standard dimensions (1 m x 1 m). The induction coil shall then be rotated by 90° in order to expose the EUT to the test field with different orientations.

WORKING (TESTING) MODE OF THE EUT: MODE_1 + MODE_2.

5.2.7.4. Measurement Equipment

Type	Model	Manufacturer	Serial No.	Končar Id. No.
GENERATOR	UCS 500 M4	EM Test	1202-05	D887348
ANTENNA	MS 100	EM Test	-	EMC 21583 06 08 11
MOTOR VARIAC	MV 2616	EM Test	V0628101593	902502

5.2.7.5. Test results

ATMOSPHERIC CONDITIONS; Temperature: 20°C; Humidity: 42%; Air pressure: 997 mbar

Orientation	Field	Result
X-axis	100, 1000 A/m	Pass
Y-axis	100, 1000 A/m	Pass
Z-axis	100, 1000 A/m	Pass

Photo of the measurement is on a picture 27:



Picture 27: Photo of the measurement setup and testing

Final Test Result: PASS